

## Product Summary

$V_{DS} = 1200\text{ V}$   
 $I_D@25^\circ\text{C} = 102\text{ A}$   
 $R_{DS(ON)} = 20\text{ m}\Omega$   
 AEC-Q101 in Progress

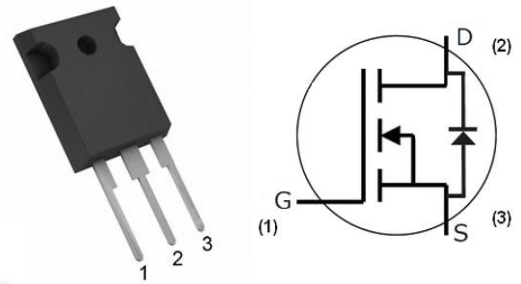

TO-247-4

## Features

- High Blocking Voltage
- High Frequency Operation
- Low on-resistance
- Fast intrinsic diode with low reverse recovery

## Benefits

- Higher System Efficiency
- Parallel Device Convenience without thermal runaway
- High Temperature Application
- Hard Switching & Higher Reliability
- Easy to drive

## Applications

- Motor Drives
- Solar / Wind Inverters
- EV Charging Station
- AC/DC converters
- DC/DC converters
- Uninterruptable power supplies

## Maximum Ratings ( $T_C=25^\circ\text{C}$ unless otherwise specified)

Parameter	Symbol	Test conditions	Value	Unit
Drain - Source Voltage	$V_{DSmax}$	$V_{GS}=0\text{V}$ , $I_D=100\mu\text{A}$	1200	V
Gate - Source Voltage (dynamic)	$V_{GSmax}$	AC ( $f>1\text{ Hz}$ )	-10 / +25	V
Gate - Source Voltage (static)	$V_{GSop}$	static	-5 / +20	V
Continuous Drain Current	$I_D$	$V_{GS} = 20\text{V}$ , $T_C=25^\circ\text{C}$	102	A
		$V_{GS} = 20\text{V}$ , $T_C=100^\circ\text{C}$	72	
Pulsed Drain Current	$I_{D(pulse)}$	$T_C=25^\circ\text{C}$	210	A
Short Circuit Capability	$t_{SC}$	$V_{DD}=800\text{V}$ , $V_{GS}=20\text{V}$	5	$\mu\text{S}$
Short Circuit Capability	$I_{DS}$	$V_{DD}=800\text{V}$ , $V_{GS}=20\text{V}$	600	A
Total power dissipation	$P_D$	$T_C=25^\circ\text{C}$	500	W
Operating Junction Temperature	$T_J$		-55 to 175	$^\circ\text{C}$
Storage Temperature	$T_{STG}$		-55 to 175	$^\circ\text{C}$

Stresses exceeding those listed in the Maximum Ratings table may damage the device. If any of these limits are exceeded, device functionality should not be assumed, damage may occur and reliability may be affected.

## Electrical Characteristics (T<sub>C</sub>=25°C unless otherwise specified)

Parameter	Symbol	Test conditions	Min	Typ	Max	Unit
Drain-Source Breakdown Voltage	V <sub>(BR)DSS</sub>	V <sub>GS</sub> = 0V, I <sub>D</sub> = 100μA	1200			V
Gate Threshold Voltage	V <sub>GS(th)</sub>	V <sub>DS</sub> = V <sub>GS</sub> , I <sub>D</sub> = 20mA	1.9	2.5	3.8	V
		V <sub>DS</sub> = V <sub>GS</sub> , I <sub>D</sub> = 20mA, T <sub>J</sub> = 150°C		1.9		
		V <sub>DS</sub> = V <sub>GS</sub> , I <sub>D</sub> = 20mA, T <sub>J</sub> = 175°C		1.8		V
Zero Gate Voltage Drain Current	I <sub>DSS</sub>	V <sub>DS</sub> = 1200V, V <sub>GS</sub> = 0V	0	5	100	μA
Gate-Source Leakage Current	I <sub>GSS</sub>	V <sub>GS</sub> = 20V, V <sub>DS</sub> = 0V	0	10	200	nA
Gate-Source Leakage Current	I <sub>GSS</sub>	V <sub>GS</sub> = -5V, V <sub>DS</sub> = 0V	-200	-10	0	nA
Drain-Source On-State Resistance	R <sub>DS(on)</sub>	V <sub>GS</sub> = 20V, I <sub>D</sub> = 50 A		20	29	mΩ
		V <sub>GS</sub> = 20V, I <sub>D</sub> = 50 A, T <sub>J</sub> = 150°C		32		
		V <sub>GS</sub> = 20V, I <sub>D</sub> = 50 A, T <sub>J</sub> = 175°C		36		
Transconductance	g <sub>fs</sub>	V <sub>DS</sub> = 20V, I <sub>D</sub> = 50 A,		36		S
		V <sub>DS</sub> = 20V, I <sub>D</sub> = 50 A, T <sub>J</sub> = 150°C		34		
		V <sub>DS</sub> = 20V, I <sub>D</sub> = 50 A, T <sub>J</sub> = 175°C		31		
Input capacitance	C <sub>iss</sub>	V <sub>DS</sub> = 1000V, V <sub>GS</sub> = 0V f = 1MHz		4900		pF
Output capacitance	C <sub>oss</sub>			225		
Reverse transfer capacitance	C <sub>rss</sub>			13		
C <sub>oss</sub> Stored Energy	E <sub>oss</sub>			146		
Total gate charge	Q <sub>g</sub>	V <sub>DS</sub> = 800V, V <sub>GS</sub> = -5V / 20V I <sub>D</sub> = 50 A,		256		nC
Gate-source charge	Q <sub>gs</sub>			71		
Gate-drain charge	Q <sub>gd</sub>			98		
Internal gate input resistance	R <sub>g(int)</sub>	f = 1MHz, I <sub>D</sub> = 0A		2.0		Ω
Turn-On Switching Energy	E <sub>ON</sub>	V <sub>DS</sub> = 800 V, V <sub>GS</sub> = -5V/20V, I <sub>D</sub> = 50A, R <sub>G(ext)</sub> = 2Ω, L = 200μH		1250		μJ
Turn-Off Switching Energy	E <sub>OFF</sub>			175		
Turn-On Delay Time	t <sub>d(on)</sub>			15		ns
Rise Time	t <sub>r</sub>			44		
Turn-Off Delay Time	t <sub>d(off)</sub>			43		
Fall Time	t <sub>f</sub>			12		
Avalanche Capability	E <sub>AS</sub>	V <sub>DD</sub> = 100V, V <sub>GS</sub> =20V, L=2mH		784		mJ
Avalanche Capability	I <sub>AV</sub>	V <sub>DD</sub> = 100V, V <sub>GS</sub> =20V, L=2mH		28		A

### Reverse Diode Characteristics (T<sub>C</sub>=25°C unless otherwise specified)

Parameter	Symbol	Condition	Min	Typ	Max	Unit
Diode Forward Voltage	V <sub>SD</sub>	V <sub>GS</sub> = -5V, I <sub>SD</sub> = 25A,		3.8		V
		V <sub>GS</sub> = -5V, I <sub>SD</sub> = 25A, T <sub>J</sub> = 150°C		3.5		
		V <sub>GS</sub> = -5V, I <sub>SD</sub> = 25A, T <sub>J</sub> = 175°C		3.4		
Continuous Diode Forward Current	I <sub>S</sub>	V <sub>GS</sub> = -5V		95		A
Reverse Recovery time	t <sub>rr</sub>	V <sub>GS</sub> = -5V, I <sub>SD</sub> = 50A, V <sub>R</sub> = 800V, dif/dt = 1800 A/μs		30		ns
Reverse Recovery Charge	Q <sub>rr</sub>			420		nC
Peak Reverse Recovery Current	I <sub>rrm</sub>			23		A

### Thermal Characteristics

Parameter	Symbol	Condition	Min	Typ	Max	Unit
Thermal Resistance (per device)	R <sub>th(j-c)</sub>	junction-case		0.23	0.3	°C/W

## Typical Performance

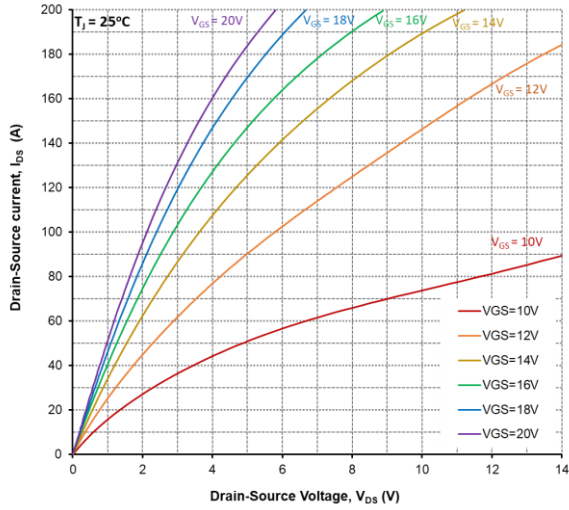

Figure 1. Output Characteristics,  $T_J = 25^\circ\text{C}$

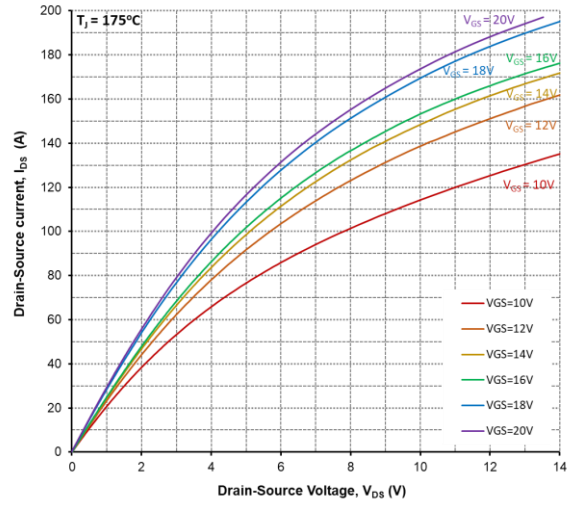

Figure 2. Output Characteristics,  $T_J = 175^\circ\text{C}$

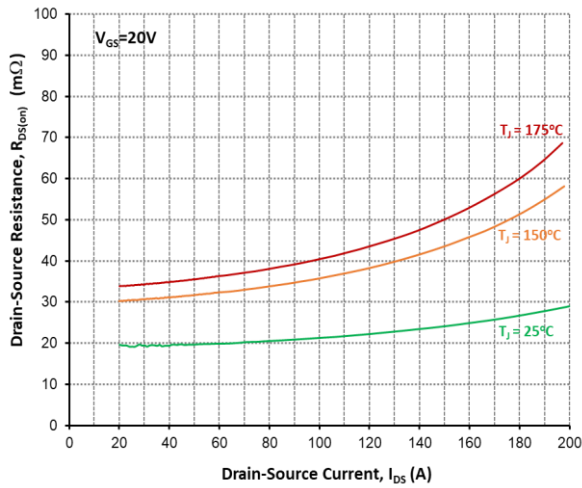

Figure 3. On-Resistance vs. Drain Current For Various Temperatures

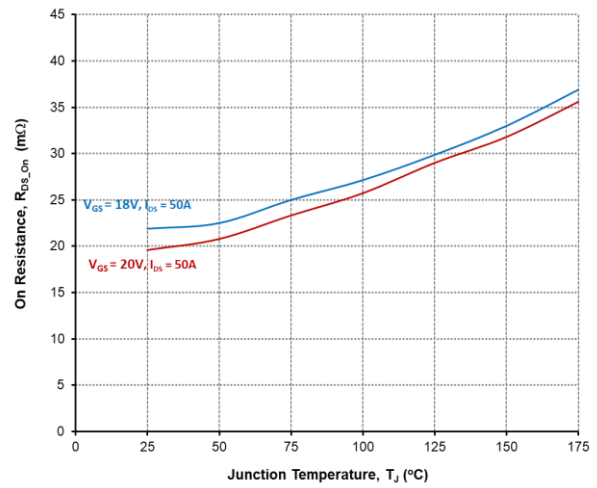

Figure 4. On-Resistance vs. Temperature

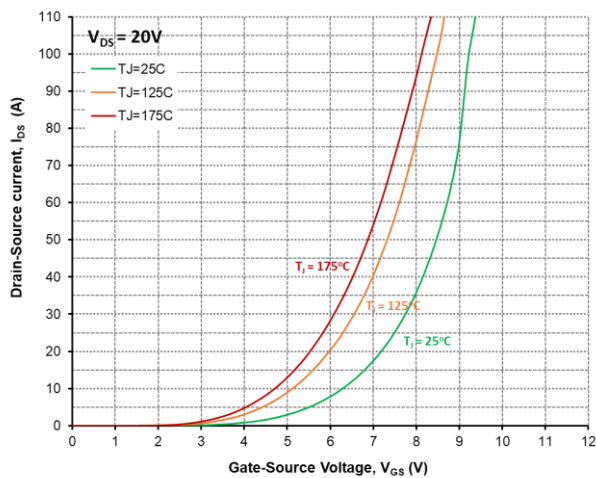

Figure 5. Transfer Characteristic For Various Junction Temperatures

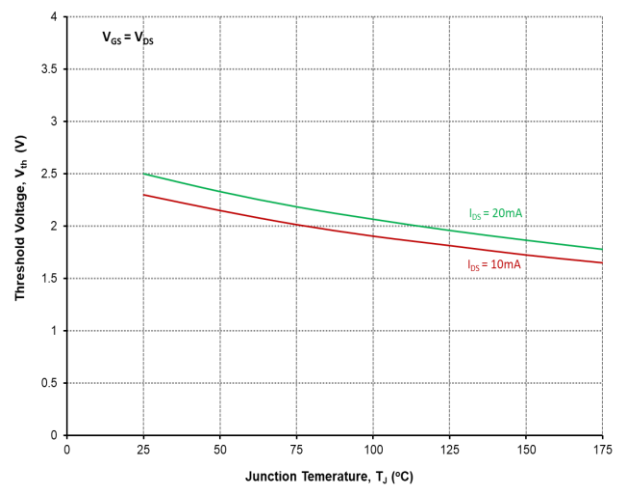

Figure 6. Threshold Voltage vs. Temperature

## Typical Performance

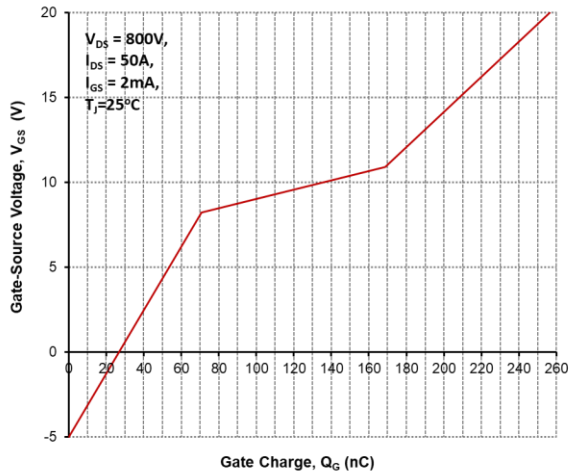

Figure 7. Gate Charge Characteristics

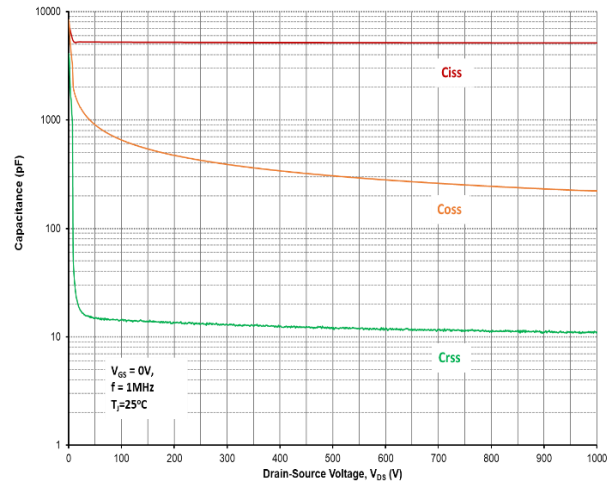

Figure 8. Capacitances vs. Drain-Source Voltage (0-1000V)

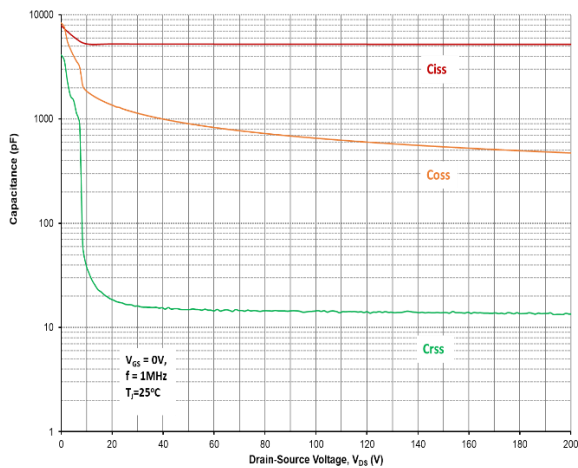

Figure 9. Capacitances vs. Drain-Source Voltage (0-200V)

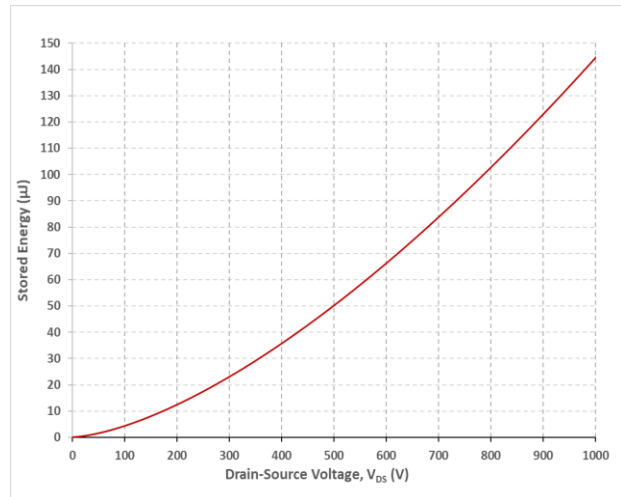

Figure 10. Output Capacitor Stored Energy

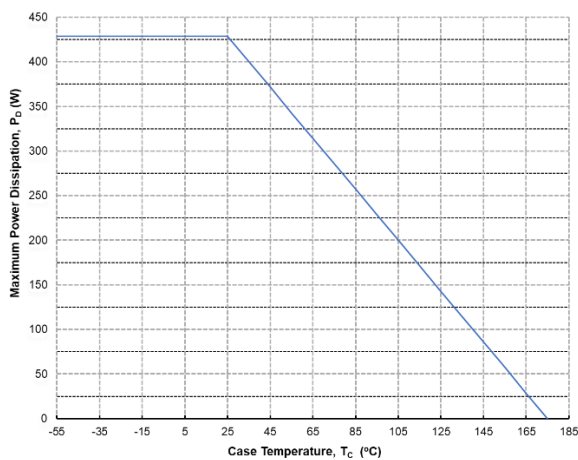

Figure 11. Maximum Power Dissipation Derating vs. Case Temperature

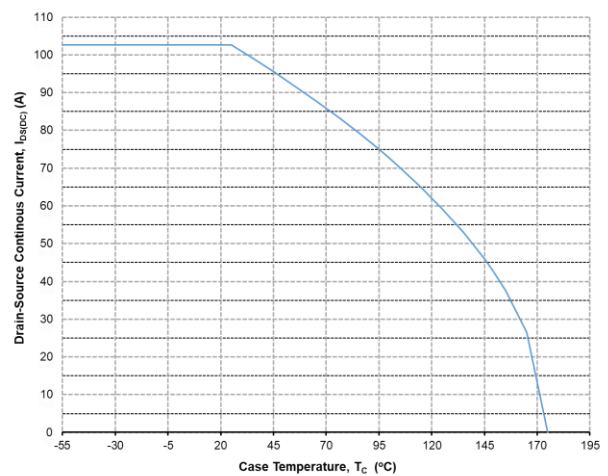

Figure 12. Continuous Drain Current Derating vs. Case Temperature

## Typical Performance

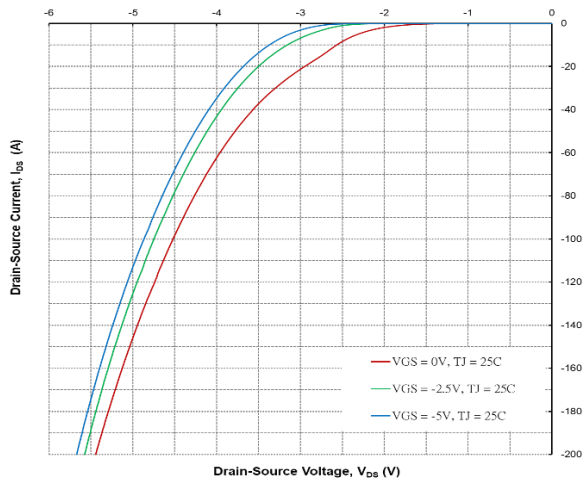

Figure 13. Body Diode Characteristics @ 25°C

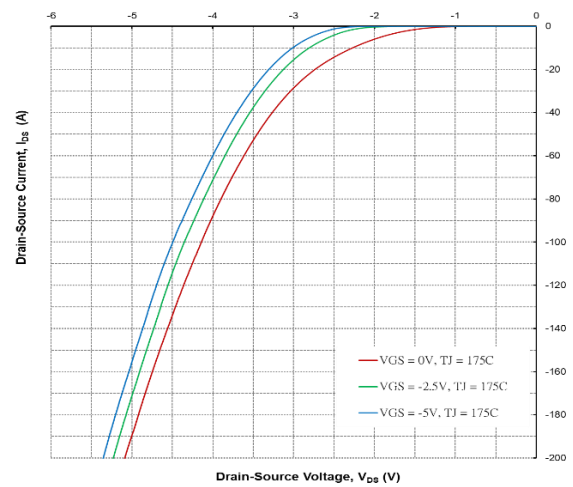

Figure 14. Body Diode Characteristics @ 175°C

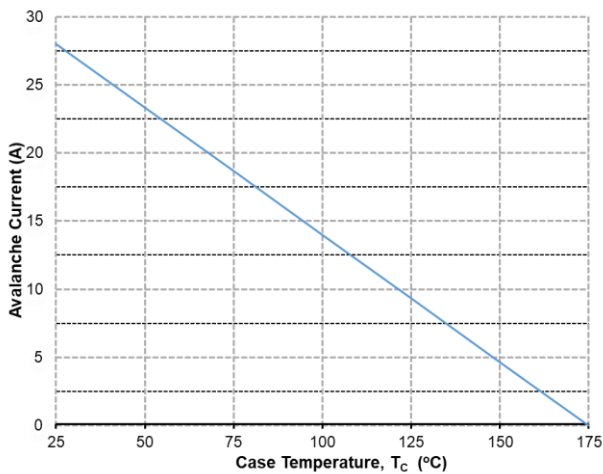

Figure 15. Single Avalanche vs. Temperature

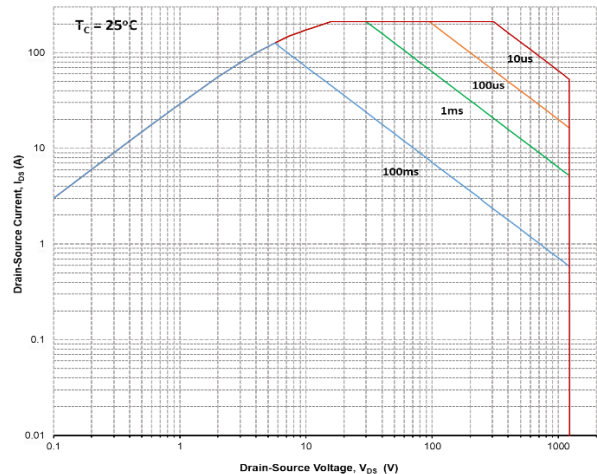

Figure 16. Safe Operating Area

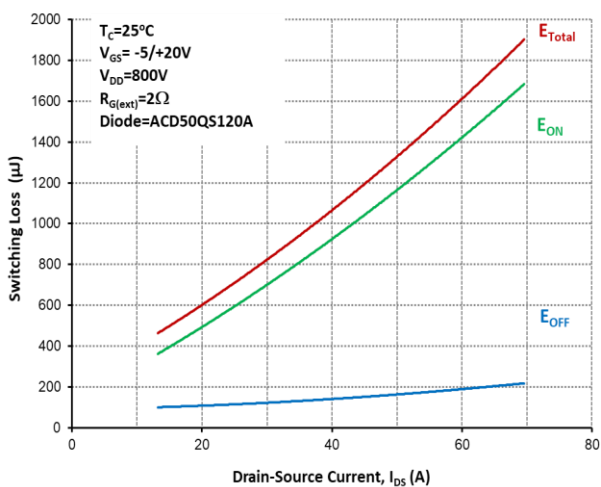
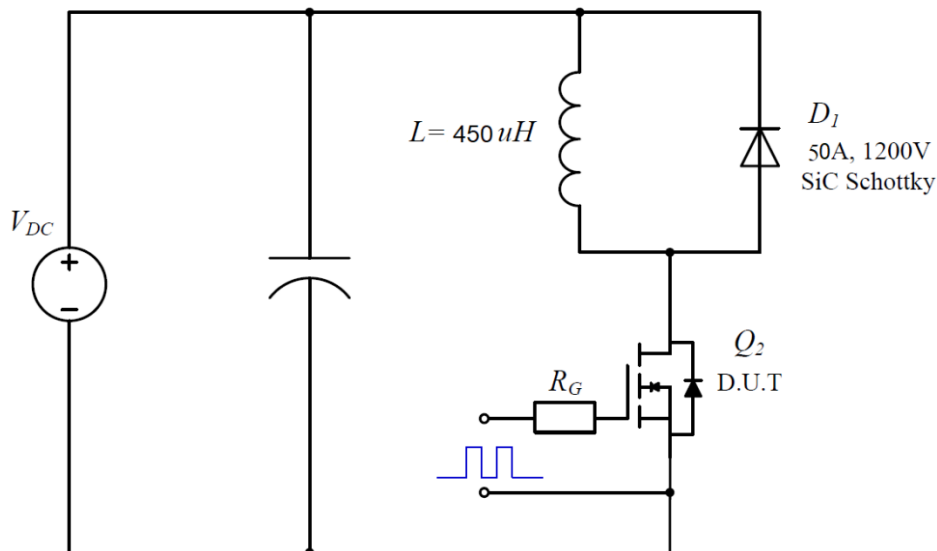
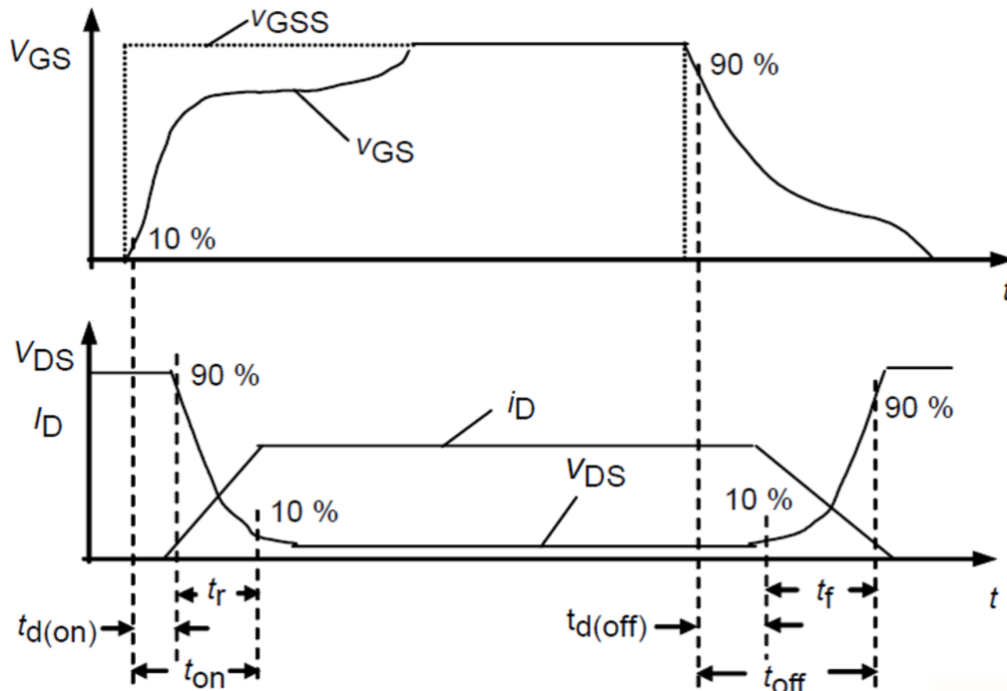

Figure 17. Clamped Inductive Switching Energy vs. Drain Current

### Switching Times Definition and Test Circuit



## Package Dimensions

(TO-247-3 Package)

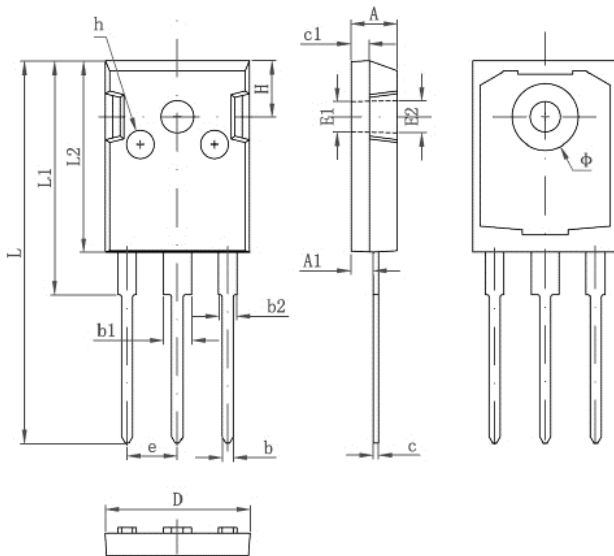

Symbol	Dimensions In Millimeters		Dimensions In Inches	
	Min	Max	Min	Max
A	4.850	5.150	0.191	0.200
A1	2.200	2.600	0.087	0.102
b	1.000	1.400	0.039	0.055
b1	2.800	3.200	0.110	0.126
b2	1.800	2.200	0.071	0.087
c	0.500	0.700	0.020	0.028
c1	1.900	2.100	0.075	0.083
D	15.450	15.750	0.608	0.620
E1	3.500 REF		0.138 REF	
E2	3.600 REF		0.142 REF	
L	40.900	41.300	1.610	1.626
L1	24.800	25.100	0.976	0.988
L2	20.300	20.600	0.799	0.811
Φ	7.100	7.300	0.280	0.287
e	5.450 TYP		0.215 TYP	
H	5.980 REF		0.235 REF	
h	0.000	0.300	0.000	0.012